

Sustainability

Bill Stuth Sr
Aqua Test Inc.
aquatestinc.com

Onsite systems are no
longer considered
temporary

Chemical products—
while an easy fix for the
homeowner / owner are
challenging for onsite
systems

Chemical products

- Antibacterial
- Sanitizing
- Bleaches / Liquid fabric softeners
- Drain cleaning
- Floor strippers
- “Septic Safe”

Protecting the
environment and the user
at the same time should
be our priority

The onsite industry needs to:

- Realize the systems we design and install must provide the operator/owner with reliable, long lasting systems that are affordable

The onsite industry needs to:

- Educate governmental agencies, engineers, designers, installers, and operator/owners as to the value of sustainability

The minimum standards
we use to design onsite
systems normally do not
encourage sustainability

Sustainability

How do we get there?

We must think “out of the box”



We, as an industry, need to get rid of all the boxes and start thinking creatively to provide sustainable and affordable onsite systems



Where can he find the information he needs?

Sharing of knowledge

Understand what you are
doing—

Don't get so far out of the
box you create problems



Computerized control system—cost was in excess of \$250,000—flows were 14,000 gpd—system was abandoned as it never worked correctly



A water cooling coil installed in a grease trap

Dangerous and illegal!



Membrane Filtration system installed to treat HSW—
system did not work

A sustainable onsite
system provides
protection for both the
consumer and the
environment

Sustainability requires:

- O & M for the life of the system
- System needs to be “maintenance friendly”
- Consideration for “peak flows” and “organic loading”
- Flexibility for the operation of the system
- Recovery features
- Operation costs must be affordable
- Educate the user

PROCESS COMPATIBILITY

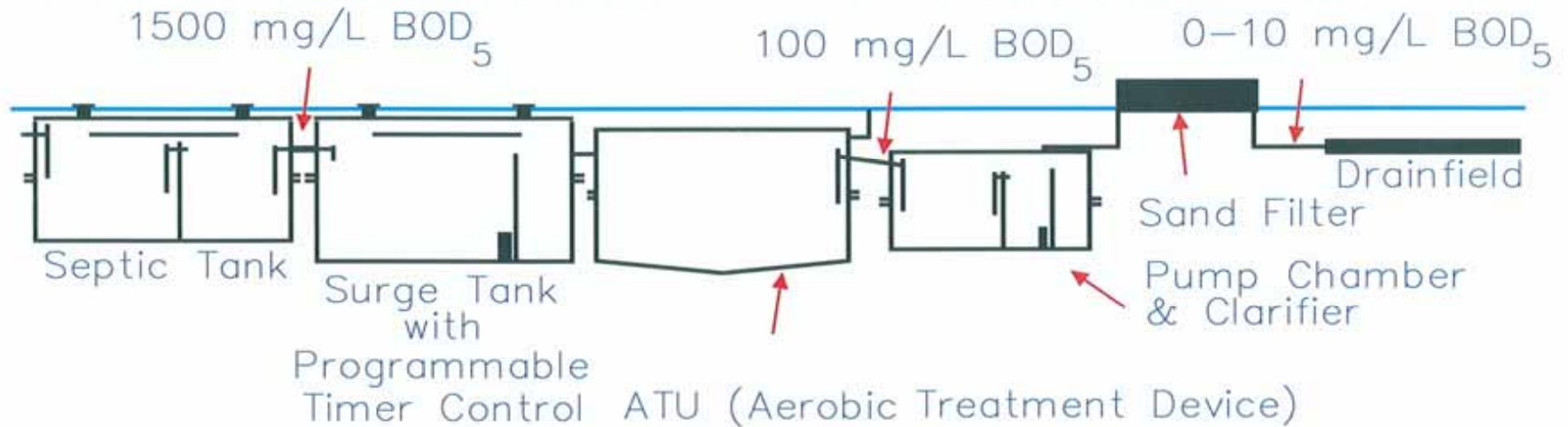

The first two tanks address peak flows. The balance of the system was designed based upon organic loading.

Diversity of Flows from a Supermarket

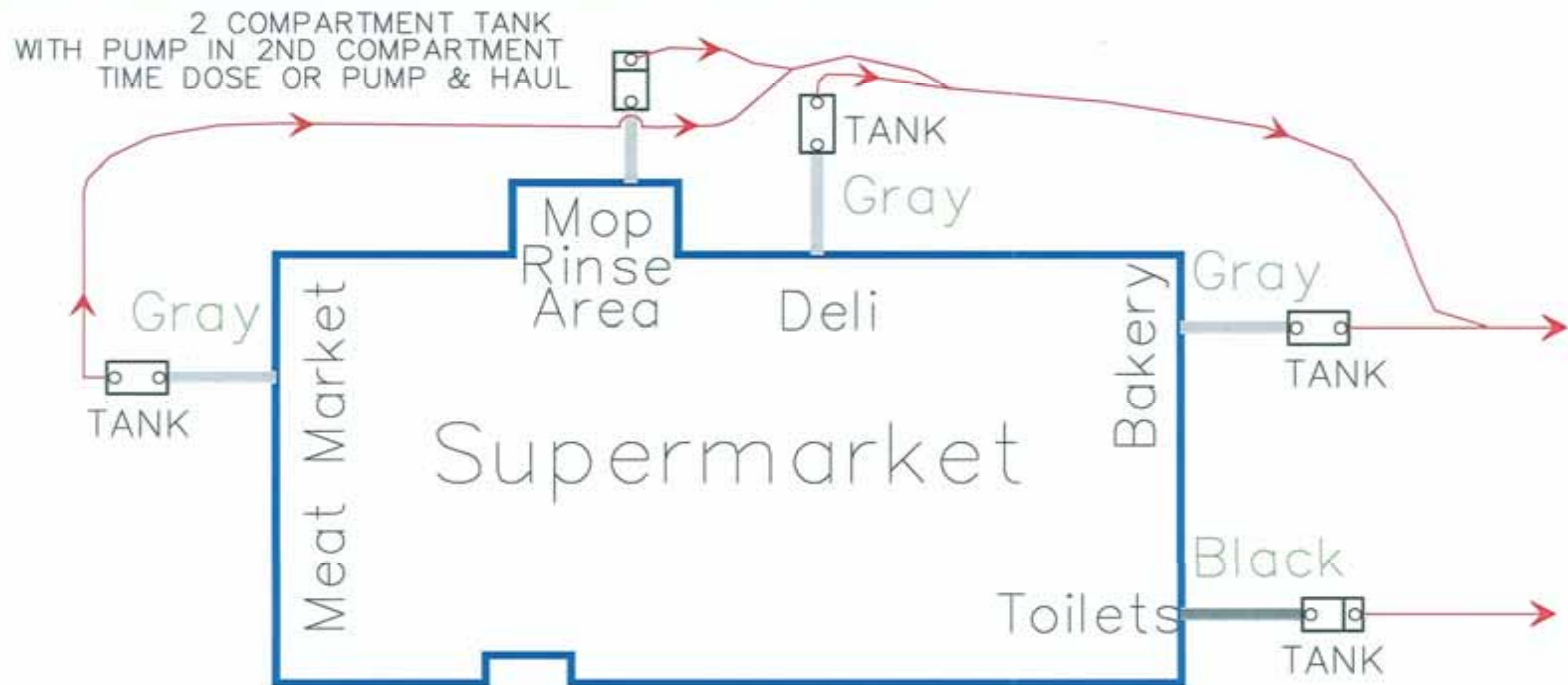

Separating the plumbing provides the ability to determine waste characteristics of each department and isolate a area that may cause the system to fail.

Baffled Compartment Wall

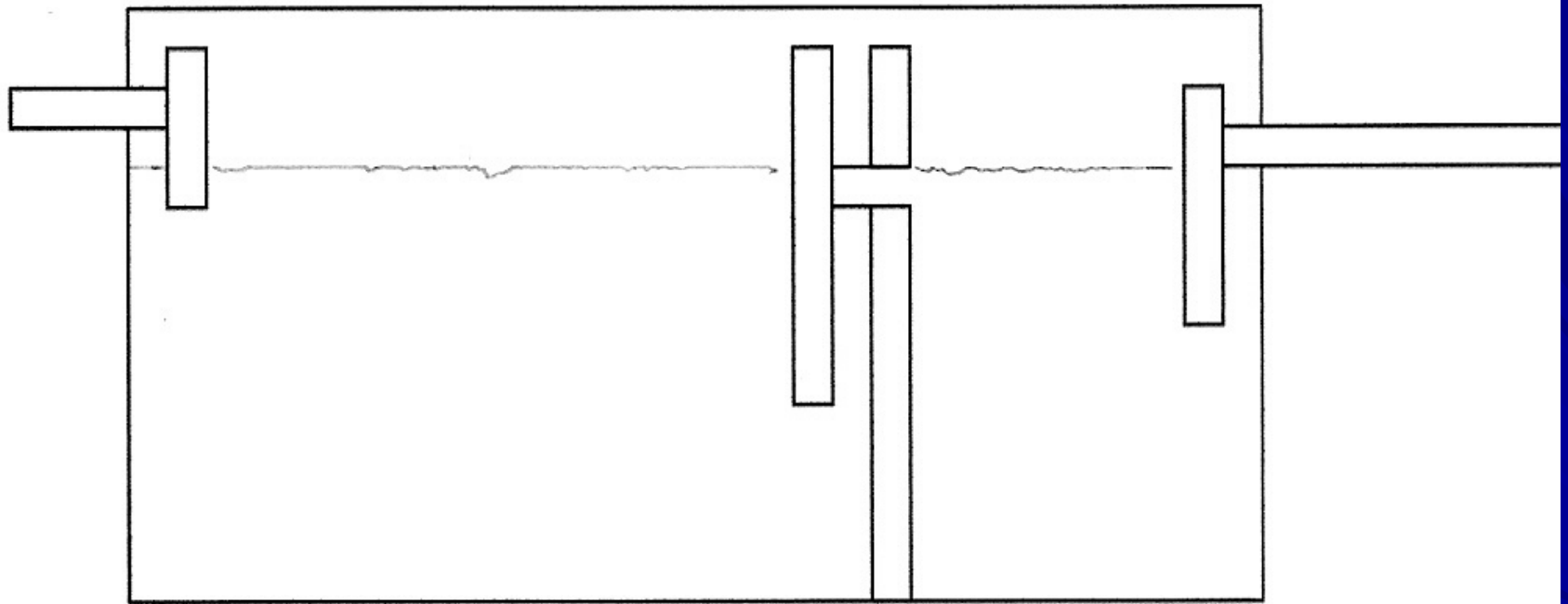

Typical tank in use today

Longer detention times
allow for better
separation and
biological
decomposition of solids

Tank
increases
distance from
the inlet to the
outlet
prolonging the
detention time

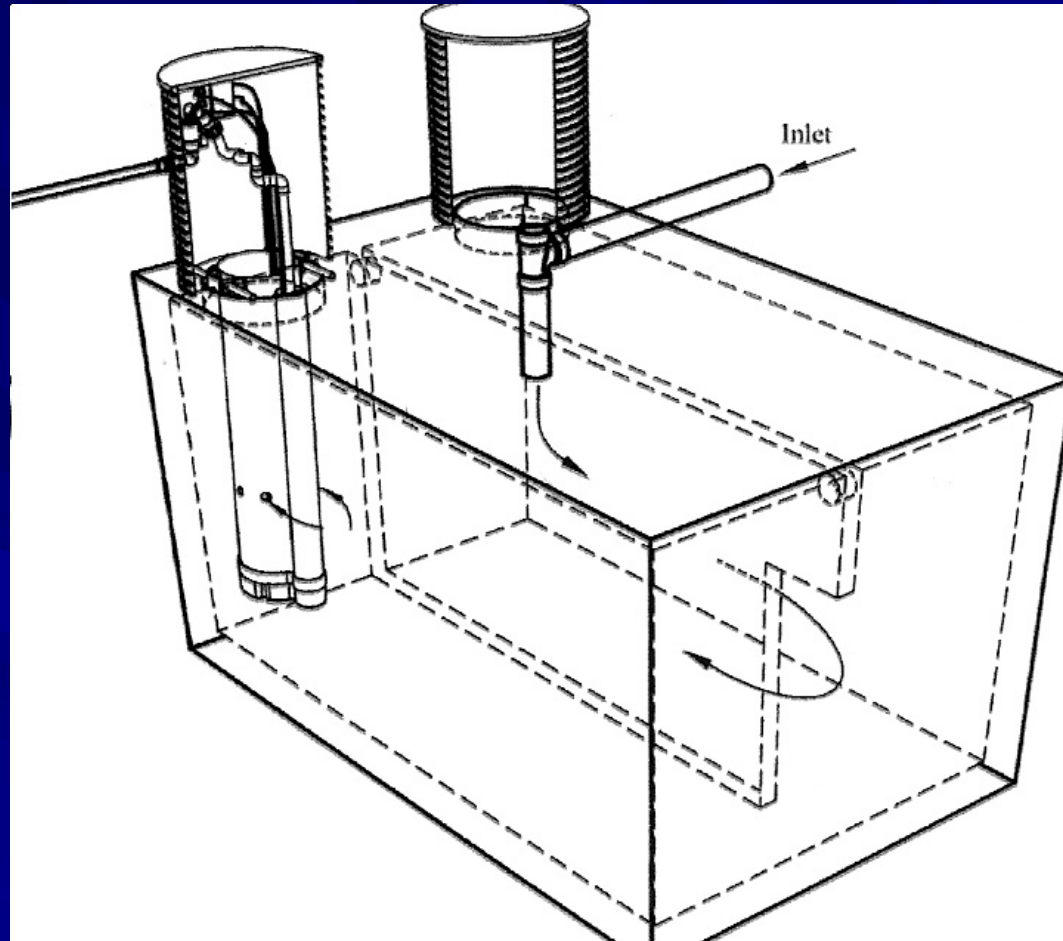

Commercial
tank
designed to
increase
detention
time

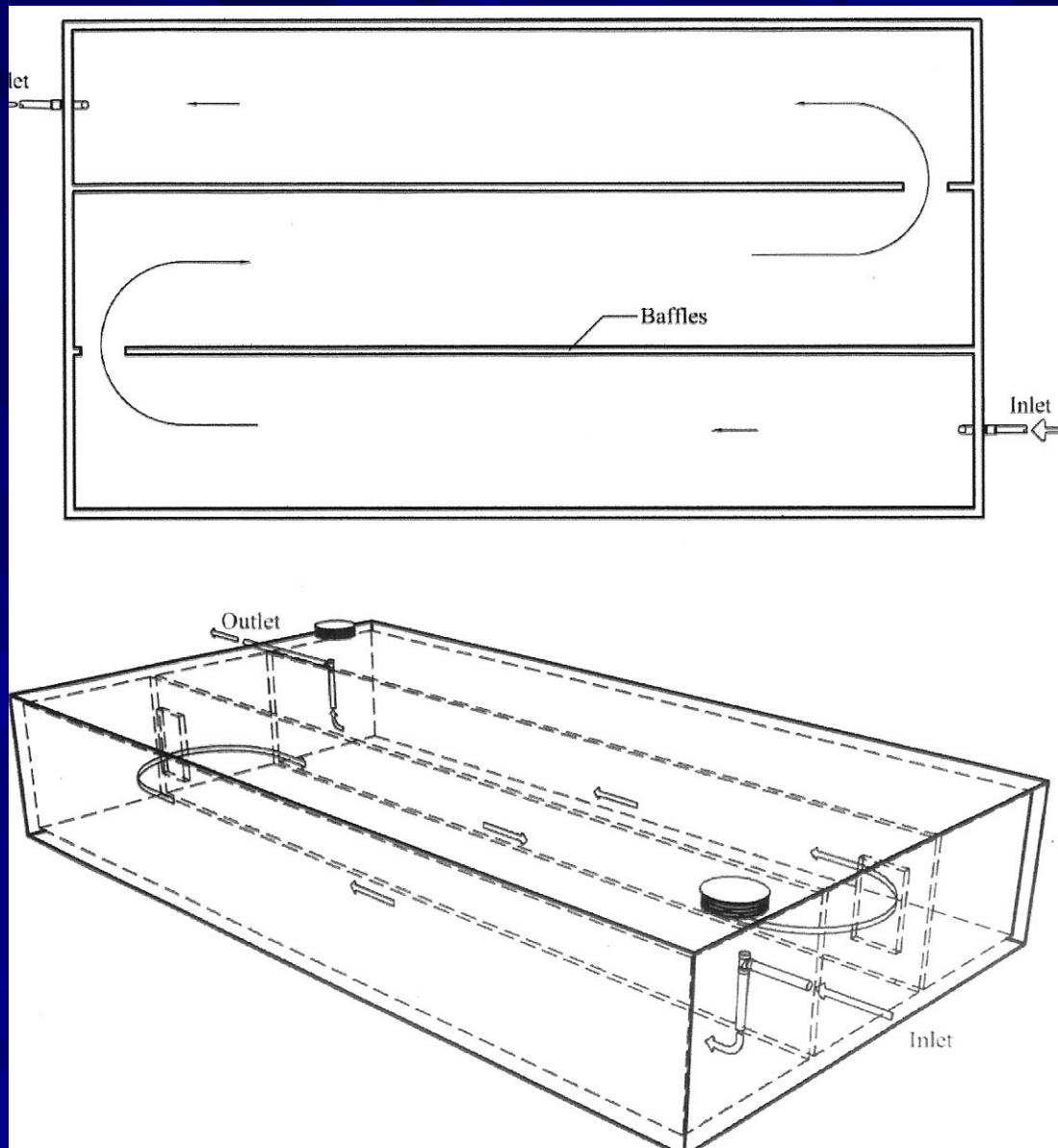

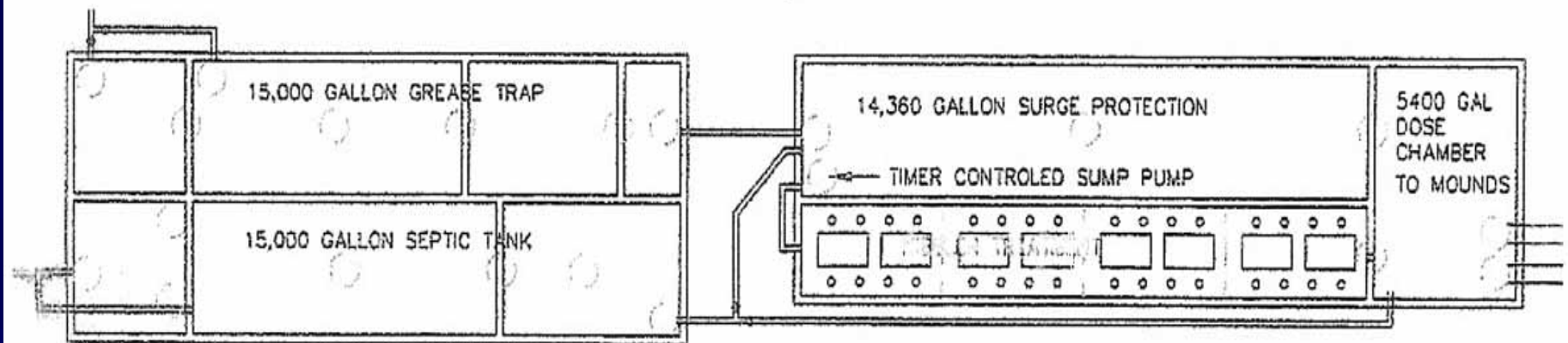

Features of this cast in place tank include:

- Common wall enhances temperatures in both tanks
- 1st compartment is a trash tank capable of being bypassed during pumping
- Black water can be sent to the drainfield pump tank or be co-mingled with the grey water in the surge tank
- Surge tank has the ability to supply the ATU with flows evenly over a 24-hour period

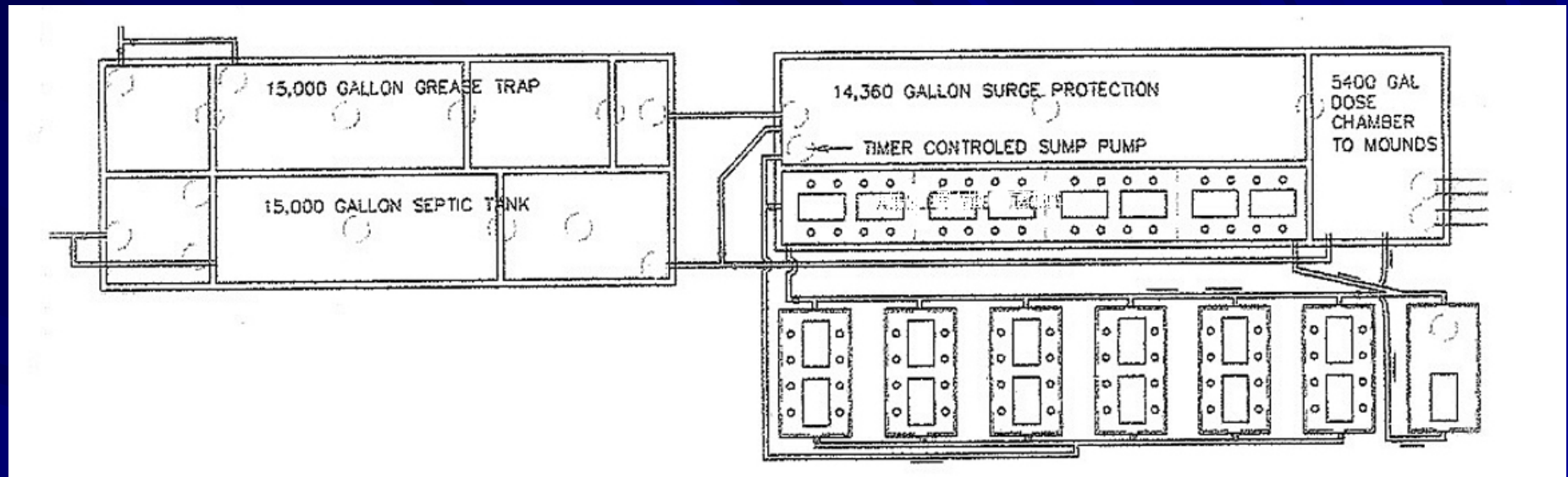

In a performance based system
whenever the inside operation
changes you may have to change
the treatment components

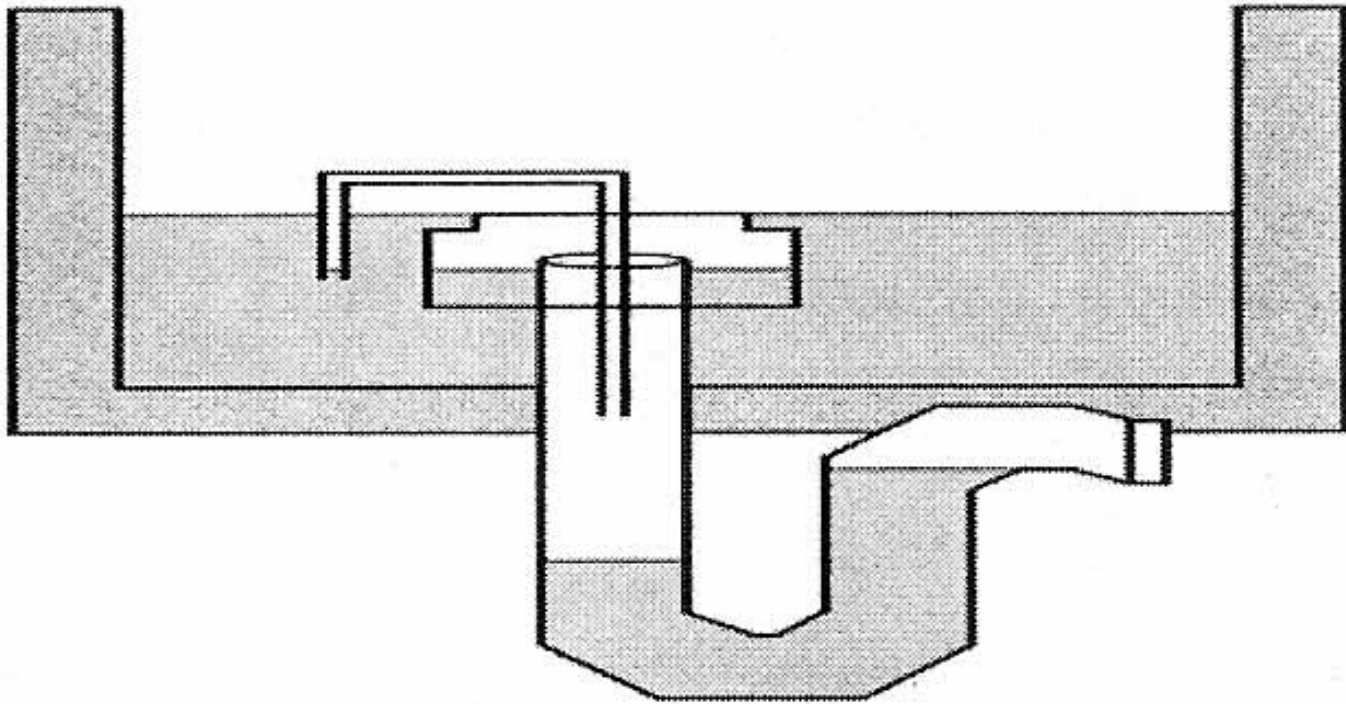

This configuration does not provide a sludge accumulation area—sludge discharges directly to the disposal system



13,000 GPD siphon---disposal field is located one mile from the septic tank



Siphon after backfill

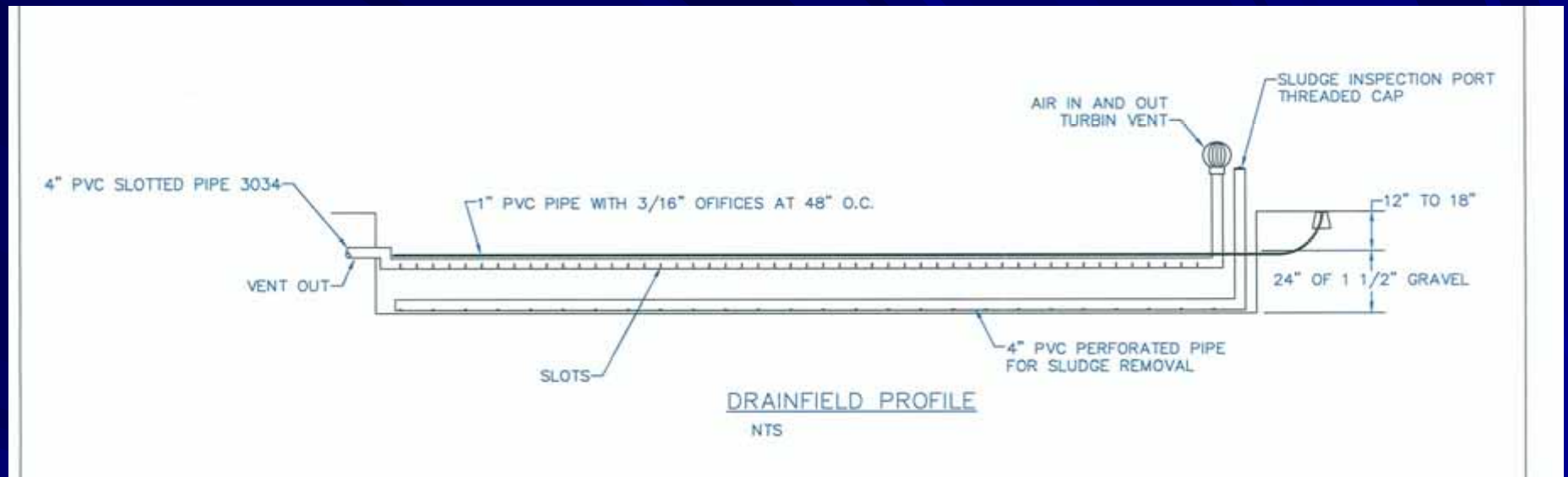

Drainfield features include:

- Recovery features
- Ease of maintenance
- Air enhanced treatment
- Drainfield depth increases the life of the drainfield

Make a system recoverable by eliminating the D-boxes and installing drop boxes

Drop boxes that are flooded can be pumped out.

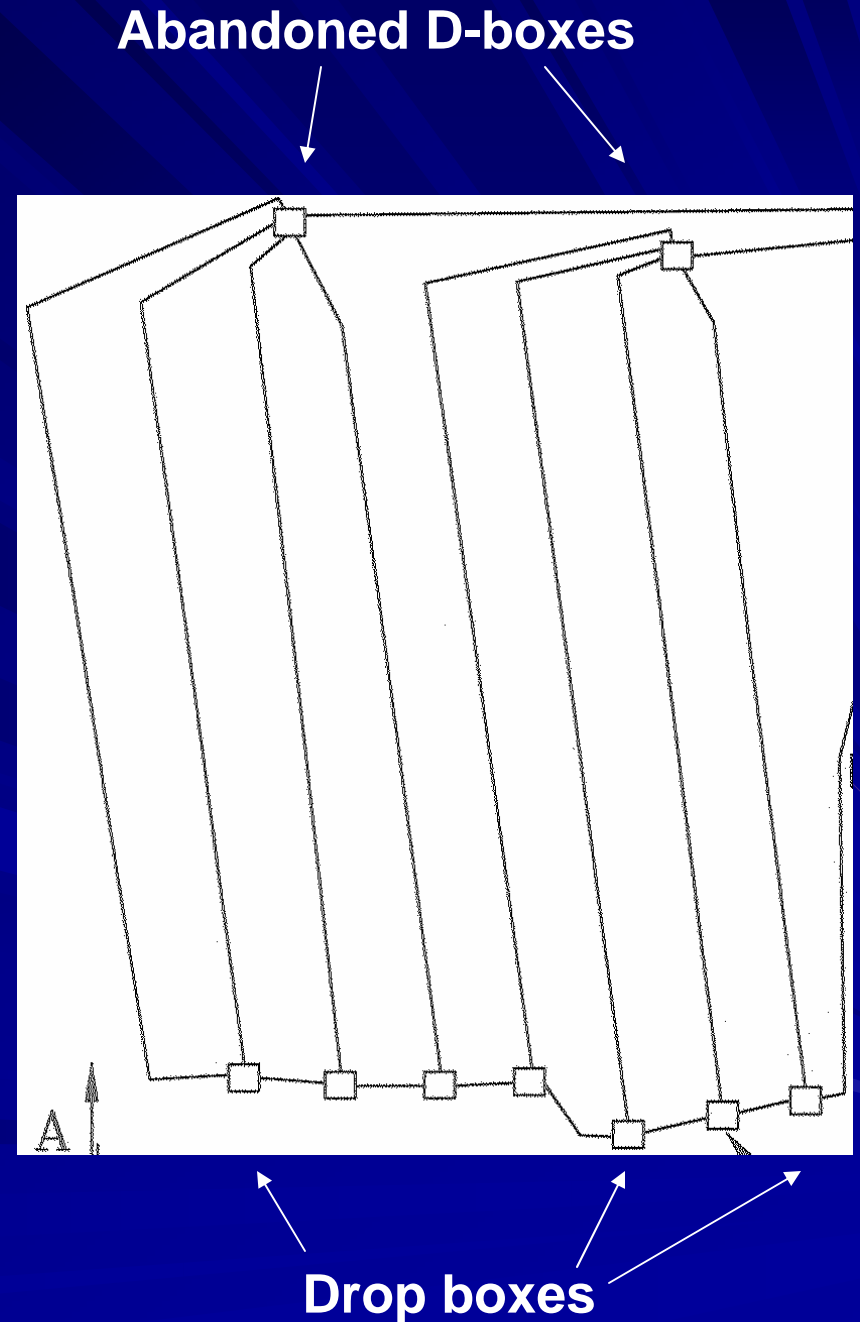



Removing contaminated sludge—a result of emulsification in the septic tank



After the removal of the sludge



Filter fabric placed on side walls to prevent infiltration of blow sand



Same site



Large gravel bed converted to trenches to provide side walls

End View

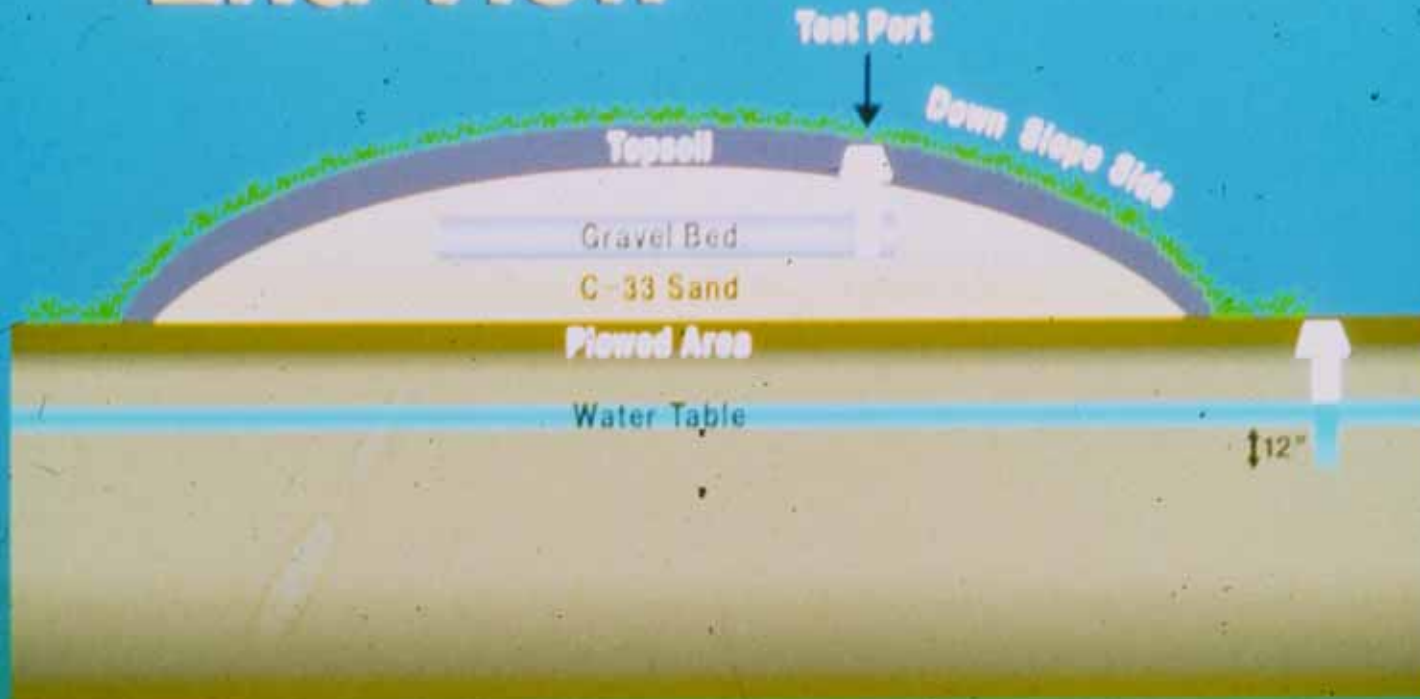



Steep slope—leaking mound



Mound installed on slope—trenches used rather than a bed



Maximum organic loading to the interface of a RGF



Method used to maximize the interface of a RGF



Piping allows air to be introduced into gravel recirc filter

Supermarket
septic tank
emulsified
and moved
the sludge
into the gravel
recirc filter



Introduction
of air to
clean and
back-flush a
gravel recirc
filter



After one back-flush the system was checked to determine if the system needed back-flushing a second time



Thank you!